

ThermPro



Model No. : TP-15H

DIGITAL INSTANT READ THERMOMETER
INSTRUCTION MANUAL

20191021 EN

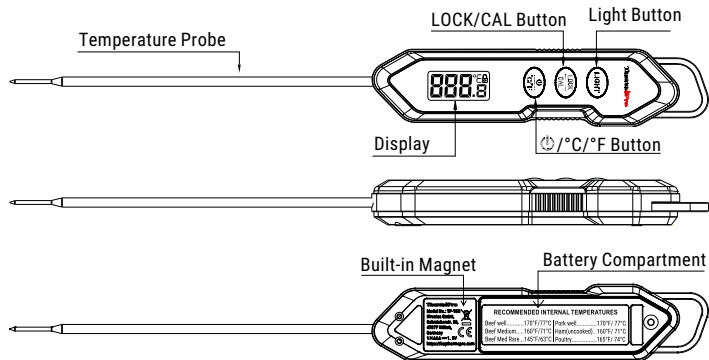

Product Features and Specification

1. Display: Displays the temperature measured by the probe instantly
2. Super Fast Temperature Probe: Insert temperature probe into meat to receive internal meat temperature within 4 seconds
3. IPX6 Grade Waterproof: can be washed under running water without fear
4. Backlight for easy reading temperature
5. Calibration Feature: allows users to re-calibrate the thermometer
6. Auto-Off: Turns off automatically if 10 minutes no use
7. Built-in Magnet for Easy Storage
8. Food Grade Stainless Steel Probe: Length: 5.4 inch (136 mm)
9. Temperature range: -58 °F ~ 572°F (-50 °C ~ 300 °C). If the temperature is below -58 °F (-50 °C) or above 572 °F (300 °C), LL. L or HH.H will show on the display
10. Resolution: 0.1 °C/°F
11. Temperature Accuracy: ±0.9°F (±0.5°C) in range between 32 to 212°F (0 to 100°C)
12. Power supply: 1*AAA 1.5V

Buttons

1. ON/OFF Button: Press once to turn ON/OFF the unit. Press and hold for 3 seconds to select which temperature unit to display.
2. LOCK/CAL Button: Press once to lock the current temperature display. Press it again to unlock the temperature display. Press and hold it for 5 seconds to calibrate the unit.
3. Light Button: Press once to turn ON/OFF the backlight.

Before first use

PLEASE READ AND FOLLOW ALL INSTRUCTIONS.

1. Make sure the battery is installed in the unit. If not, please insert or replace battery: Insert one 1*AAA battery in correct polarity (+) and (-) as indicated. Please make sure the battery cover is tightened securely.
2. Clean stainless tip: wash tip with warm soapy sponge or cloth, then rinse and dry.
3. The thermometer is now ready to use.

To measure food temperature

1. Press ON/OFF button to turn on the thermometer.
2. Press and hold the ON/OFF button for 3 seconds to select the temperature unit: °C or °F. Please note that the temperature unit will remain the last selection when you turn on the thermometer next time.
3. Insert the tip of probe into food being cooked. The thermometer will start to measure the internal food temperature.
4. Press the LIGHT button to turn on the backlight, It will automatically turn off after 15 seconds.
5. Wait until temperature reading stabilizes on display.
6. Press the LOCK/CAL button to lock the current temperature.
7. Press ON/OFF button to turn off the thermometer. This thermometer also comes with auto-off feature: it will automatically turn off if no button is pushed in 10 minutes.

Calibration

The thermometer comes with a Calibration feature. In most cases, the thermometer was calibrated precisely at our manufacturing facility, and generally you do NOT need to calibrate the thermometer. However, after a long period of use and you believe that the temperature reading displayed by the thermometer is not accurate, you may follow the process below to re-calibrate the thermometer:

1. Use distilled or purified water to make ice cubes in your refrigerator;
2. Get a thermal insulated bottle. If you don't have one, use a beaker or a regular cup;
3. Fill the bottle with ice cubes (no less than 70% of the volume), then top off with cold distilled or purified water (no greater than 30% of the volume);
4. Stir the mixture and let it sit for 10 minutes to allow the ice and water to reach its temperature equilibration;
5. Turn on the thermometer and hold the LOCK/CAL button for 5 seconds to enter Calibration mode. CAL will begin flashing for a few seconds and then the current temperature reading will begin to flash which means the thermometer is in Calibration mode;
6. Immerse the probe in the ice/water mixture and make sure not to touch the sides of the container. Wait till the temperature reading drops to its lowest value, which should be around 32°F or 0°C. If the temperature of the ice/water mixture is not within 28°F to 36°F (or -2°C to +2°C), the calibration can't be continued: you will need to follow the above steps to re-make the ice/water mixture;
7. Hold the LOCK/CAL button for 3 seconds to confirm the calibration and exit the Calibration mode.

Note:

The Calibration mode will only last for 15 seconds. If you're unable to finish the calibration within 15 seconds, the thermometer will automatically exit Calibration mode.

Undo-Calibration

If you want to undo the calibration and go back to the default calibration setting, please follow the below steps:

1. Turn on the thermometer and hold the LOCK/CAL button for 5 seconds to enter Calibration mode;
2. When you see temperature reading begins flashing, press and hold the Light button for 3 seconds. The temperature reading will stop flashing and the calibration is set to the default setting.

Helpful hints

- When measuring multiple or different foods and meats, it may be desirable to cool the probe by rinsing the tip with cold water between readings.
- It is recommended that you wipe the probe tip clean between readings. This is especially important when taking readings from different foods and meats.
- The thermometer is designed for temporary, hand held use. Do not use in an oven. Do not leave inserted in extremely hot foods or liquids (anything over 572°F) for more than 1 minute.
- Always take your reading in the thickest available portion of meat. Thin portions of meat are difficult to measure because they tend to cook through fast. Avoid touching bone. If the tip touches the bone or heavy fat area of the meat, or if the tip is not deep enough, take a second reading to ensure accuracy.
- Not intended for use by persons ages 12 or under.

Care of your thermometer

- Do not touch the stainless portion of the thermometer during or right after measuring temperatures since it will be hot.
- Do not leave exposed to extreme high or low temperatures as this will damage electronic parts and plastics.
- Do not leave the thermometer inserted in food during cooking.

- Remove battery if stored for more than four months.
- Do not subject the unit to excessive force, shock, dust, temperature or humidity.
- Do not immerse the unit in water.
- Do not remove any screws.
- Do not dispose this unit in a fire. IT MAY EXPLODE.
- Keep unit away from children. The unit or parts of the unit might be a choking hazard.
- Dispose of the unit legally and recycle when possible.

Disposal

You can help protect the environment! Please remember to respect the local regulations. Hand in the non-working electrical equipment to an appropriate waste disposal center.

Limited one-year warranty

ThermoPro warrants this product to be free of defects in parts, materials and workmanship for a period of one year, from date of purchase.

Should any repairs or servicing under this warranty be required, contact Customer Service by phone or email for instructions on how to pack and ship the product to ThermoPro.

This warranty gives you specific legal rights and you may also have other rights which vary from state to state.

Customer service

Telephone: 1-877-515-7797(USA & Canada only)

Email: service@buythermopro.com

Hours: Weekdays 8:00 AM - 8:00 PM EST(USA & Canada only)

Our website: www.buythermopro.com